

DOC 302

- 5,5 m / 6,0 m / 6,5 m - Voor tractoren 80-110 Pk / For tractors 80-110 hp

ACHTEROP GEPLAATSTE ARMMAAIER
REAR HEDGE MOWERS



DOC 302 5.5	Prijs op aanvraag
DOC 302 6.0	Prijs op aanvraag
DOC 302 6.5	Prijs op aanvraag

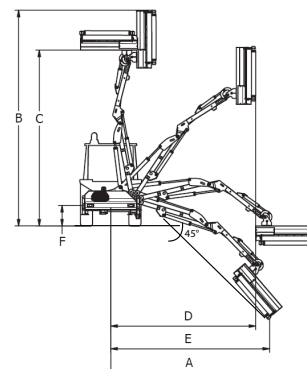

DOC 302	5.5	6.0	6.5
A (mm)	5.500	6.000	6.500
B (mm)	5.700	6.200	6.700
C (mm)	4.400	4.500	5.400
D (mm)	4.300	4.800	5.300
E (mm)	3.500	4.000	4.500
F (mm)	550	550	550

Hydraulische bosmaaier met arm met side shift en 90° achterwaartse rotatie met schokbestendige hydraulische beveiliging voor tractoren van 80/110 pk en 3500/4500 kg gewicht, ideaal voor werkzaamheden in stedelijke gebied en langs buitenwegen en voor agrarische bedrijven.

Hydraulic hedge mower with side shift and 90° rotating column with shock resistant hydraulic safety device for tractors HP 80/110 and weight 3500/4500 kg, suitable for working on local and trunk roads and farms.

ARM MAAIER- ARM MOWER

TRACTOR - TRACTOR

Model Model	Reikwijdte Extension E (mm)	Gewicht Weight (kg)	Olietank Oil tank (L)	Type kop Head (model)	Pomp Pump (l/min)	Hydr. Motor Hydraulic Motor (HP [kW])	Vermogen Power (HP [kW])	3 punts ophanging 3-point linkage	Gewicht Weight (kg)	Breedte Width (m)	PTO (tpm rpm)
DOC 302 5.5	5.500	1.100	160	30.3 TTD 125	100+20	55 (40)	80 / 110	Cat. 2	3.500	2,4	540
DOC 302 6.0	6.000	1.150	160	30.3 TTD 125	100+20	55 (40)	80 / 110	Cat. 2	4.000	2,4	540
DOC 302 6.5	6.500	1.200	160	30.3 TTD 125	100+20	55 (40)	80 / 110	Cat. 2	4.500	2,4	540

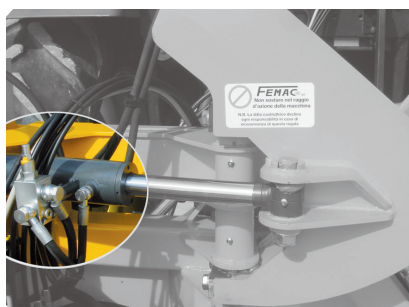

SCHOKBESTENDIGE HYDRAULISCHE BEVEILIGING
SHOCK RESISTANT HYDRAULIC SAFETY DEVICE

TECHNISCHE SPECIFICATIES EN STANDAARD UITRUSTING

- Frame – 1e en 2e arm uitgevoerd in hoogwaardig staal ST.52
- 90 ° rotatiekolom en schokbestendige hydraulische beveiliging
- Drie punts ophanging CAT2
- Hydrauliek olietank 160 liter
- Dubbele tandwielpompe groep 3+2 - 100+20 l/min
- Bidirectionele hydro motor, vermogen 55 PK
- Kabelbediening met remote control, flexibele kabel, 3000 mm
- Sistema flottante di autolivellamento
- Zwevend zelfnivellerend systeem
- Draaihoek van de maaikop 200° met bovenaansluiting
- Spiraalvormige rotor met onderbroken snijmes - KC2
- Rotorsnelheid 3000 tpm
- Spanner bevestiging - Kruis koppeling
- Lucht-olie-warmtewisselaar met hoge warmte uitwisselings capaciteit
- Achterbalk met verlichting
- Klepelmaaier 1250 mm MODEL 30.3 TTD 125 met directe overbrenging

TECHNICAL FEATURES AND STANDARD EQUIPMENT

- Frame - 1st arm - 2nd arm in structural steel ST 52
- 90° rotating column and shock resistant hydraulic safety device
- Three points attachment 2nd category
- Oil tank 160 l
- Double gear pump group 3+2 - 100+20 l/min
- Bidirectional hydraulic motor HP 55 power
- Distributor with remote controls with mm 3000 flexible cables
- Self-levelling floating system
- Feeler roller recordable on 3 positions
- Head rotating angle 200° with upper attachment
- Helicoidal rotor with jointed cut blade KC2
- Number revs to rotor 3000 rpm
- Fixing tie-rods - Cardan joint
- Air-oil heat exchanger with radiating mass at high thermal exchange
- Rear underrun protection with lights
- Flail head mm 1250 MODEL 30.3 TTD 125 with direct transmission

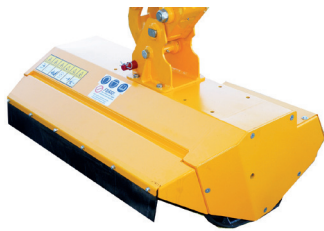

KC2

Ø max 2 cm

Standaard uitrusting
standard equipment

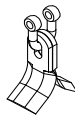

KC3

Ø max 2 cm



HC1

Ø max 4 cm

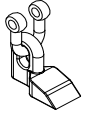

KF2

Ø max 3 cm



KF3

Ø max 3 cm

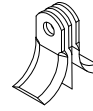

HF3

Ø max 6 cm

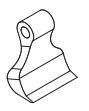

OPTIES OP AANVRAAG / MEERPRIJS

- Achteraanbouw 230 °
- Stikstofaccumulator voor 1e armophanging
- Klepelmaaier 1050 mm
- Klepelmaaier zwaar type, model 30.5
- Aan/Uit elektro-hydraulische bediening met joystick
- Riemoverbrenging "TTC" Zwaar model 30.5
- Proportionele servo met joystick
- Aankoppeling adapter CAT 1-2

ACCESSORIES ON REQUEST

- Rear attachment 230°
- Nitrogen accumulator for 1st arm suspension
- Flail head mm 1050
- Flail head, type heavy, Mod. 30.5
- On-off electro-hydraulic distributor with joystick
- Belt transmission "TTC"
- Power-assisted with joystick
- Tie rods adapter Cat. 1 o 2

AANKOPPELGEREEDSCHAP - TER VERVANGING VAN DE STANDAARD KLEPELMAAIER | TERMINAL TOOLS - IN REPLACEMENT OF THE STANDARD MULCHER

HEGGEN TRIMMER HEDGE CUTTING BAR

BF15

TAKKEN SNIJDER BRANCH CUTTING BAR

BTZ5 15

BTZ5 18

BTZ10 16

BTZ10 19

BTZ10 22

BOSMAAIER SCHIJVEN FOREST DISCS CUTTING BAR

BD2

BD3

SCHIJVEN BOSMAAIER DISC BRANCH CUTTER

DFG12

GREPPEL REINIGER DITCH CLEANER

PF60



BF15



BTZ5/10



BD2/3



DFG12



PF60